

Programming Manual

V1.0

Actuator all/nothing

4E4S-30A

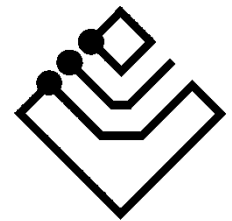

ingenium

Index

1	General Description	3
2	Technical description	4
3	Device programming	5
3.1	Naming of names	6
3.2	Inputs scripts	7
3.2.1	Programming for lighting control:	8
3.3	Additional parameters	14
4	Device diagnostics	16
5	Registers	17
5.1	RAM	17
5.2	EEPROM	18
5.2.1	Inputs table	19
5.2.2	Outputs table	19
6	Data loading to device	20
6.1	Wiring device	20
7	Wiring	21

1 GENERAL DESCRIPTION

It is an actuator with 4 digital inputs and 4 digital outputs each from 30 A. This version is indicated for capacitive lighting control, sockets, electrical appliances, etc.

This actuator is equipped with 4 free potential relay outputs, with a cut-off power of 30 A per output and 4 low voltage inputs related to the mass of the BUS. Does not have 230 V connection, so does not provide supply to BUS, it consumes supply from communication BUS. Besides, its relays have manual re-arming.

From SIDE, it is possible to allocate chains of 15 characters to identify each of the outputs and inputs. It is also possible to assign the operating mode of each of the inputs (pushbuttons, switch or blinds), and two BUS events for each of the inputs (one activation event and one deactivation event), thus allowing action to be taken on any element of the installation from the device's inputs.

Inputs:

- Low voltage inputs 5 V, 5 mA activation minimum current.
- Active when connected to bus mass.
- Maximum wiring distance to switch or push-button: 30 meters.
- Hardware and software filter configurable from the development system (SIDE).

Outputs:

- Disabled: Open relay.
- Activated: Closed relay.
- Manual re-arming possible.
- Maximum switching current 30 A per output.

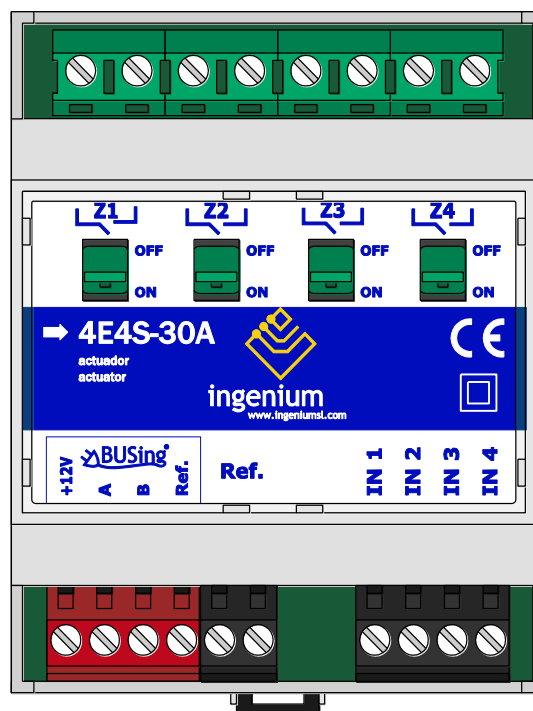

2 TECHNICAL DESCRIPTION

- 4 digital voltage inputs SELV (SELV) referring to the mass of the bus.
- 4 digital relay outputs, free of potential.
- Output relays' cut-off capacity 30 A at 230 V AC.
- Memory of the last position against power failure.
- Programmable inputs in order to work with a switch or push-button.
- 2 programmable BUS events for each input.
- Mounting DIN rail (4 modules), or in distribution box, 70 mm depth.

4E4S may be controlled from several control points: MECing, MECBUS, Smarttouch, PPL, etc.

Its control depends on the programming that has been downloaded to it, as an actuator to control electric loads or for blinds control. In case of blinds, odd outputs are for upwards movement and even outputs are for downwards movement.

This device can only be programmed from the development system (SIDE).

3 DEVICE PROGRAMMING

This device is programmed exactly as a 4E4S. The first step is to incorporate 4E4S device into the project so that it can be worked on it. In order to do so, deploy the side bar of devices (putting us on the right margin) and the actuators, they are enough to click on the 4E4S to automatically add it to the project in the first open position.

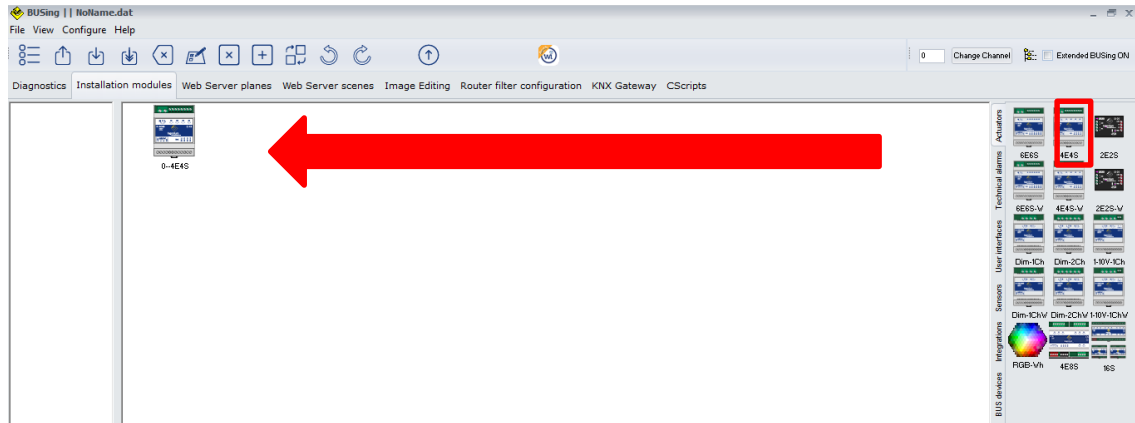

Once the new node has been included in the project, the program process starts.

Double-click on the 4E4S or, as already said, click on the 4E4S with the right mouse button and choose the option: edit properties:

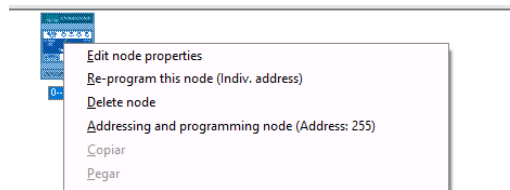

Once this is done, the 4E4S programming screen appears.

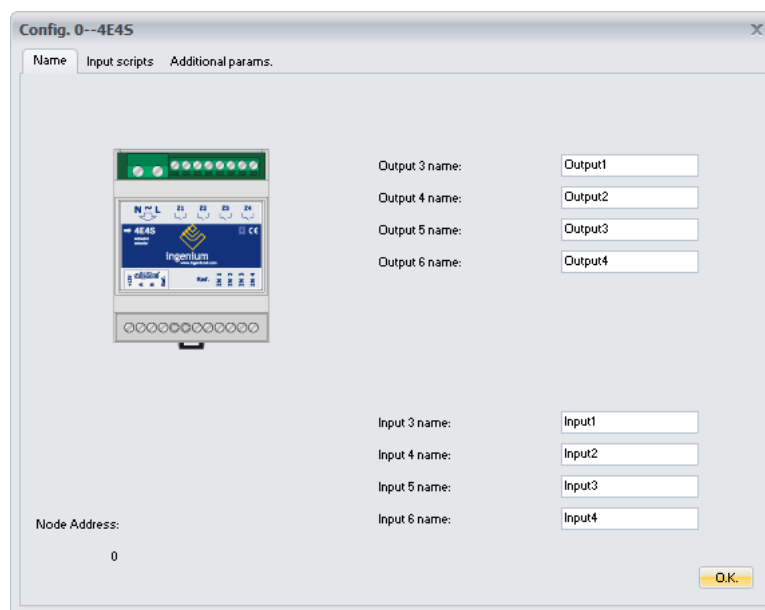

It has three tabs on: 'Name', 'Input scripts' and 'Additional parameters', which will be described below.

3.1 NAMING OF NAMES

It can be observed at the bottom left (under the photograph) the address of the node in which the 4E4S (Address 0) is located (It is reminded that in the complete SIDE there are no predefined addresses for any device, but that, as they are done, they are taking the respective addresses, starting in 0). This direction can be used, in a next step, in order to check the status of the 4E4S in the diagnostic tab.

In this tab, you can change the default name assigned by default (output1, output2...) at each of the outputs.

How can it be programmed or configured, 4E4S, for the control of electrical loads (lighting, plugs, etc.) and of blinds (or awnings, slats, etc.) will be explained on the next section. Depending on the type of load connected to the outputs, different names can be given to the outputs. For lighting control, for example if first output of 4E4S (Z1) is connected to the room lights, when scheduling names, it will be named output1 as "living".

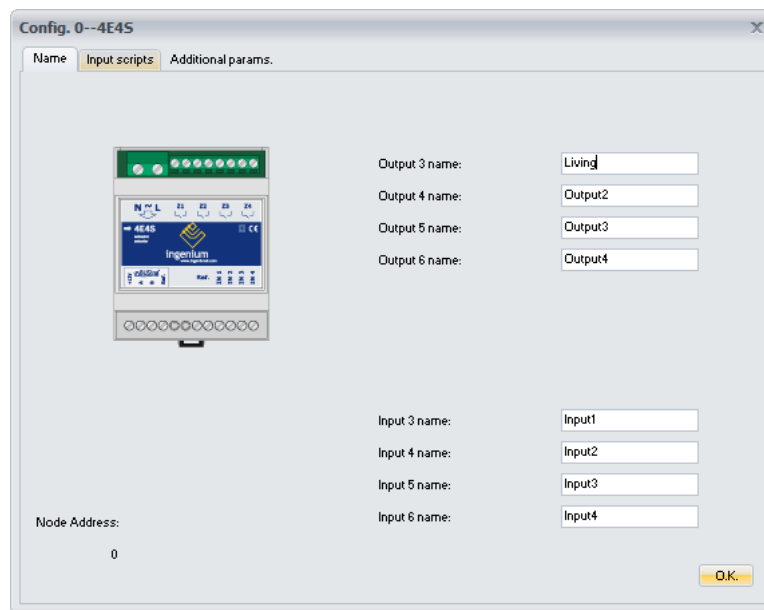

NOTE 1: ALLOWS MAXIMUM 15 CHARACTERS; NO SPACES, LETTER "Ñ", ACCENTS, OR OTHER CHARACTERS OF A KIND, CANNOT BE ADDED: *, #.....

IF THE 4E4S IS CONFIGURED (SEE "INPUTS SCRIPTS") FOR BLINDS CONTROL, THE NAMES TO BE ASSIGNED HAVE TO BE AS SHOWN.

NOTE 2: IT IS REMINDED THAT 4E4S CAN CONTROL TWO BLINDS, 2 OUTPUTS PER BLIND ARE NEEDED, ONE FOR UPWARDS MOVEMENT AND ONE FOR DOWNWARDS MOVEMENT. THEREFORE, THE NAMES OF THE OUTPUTS HAVE TO BE TWO TO TWO, CONSIDERING THE ODD OUTPUT (1) AS A RISE AND THE EVEN OUTPUT (2) AS A DECREASE. AS SHOWN IN THE IMAGE BELOW.

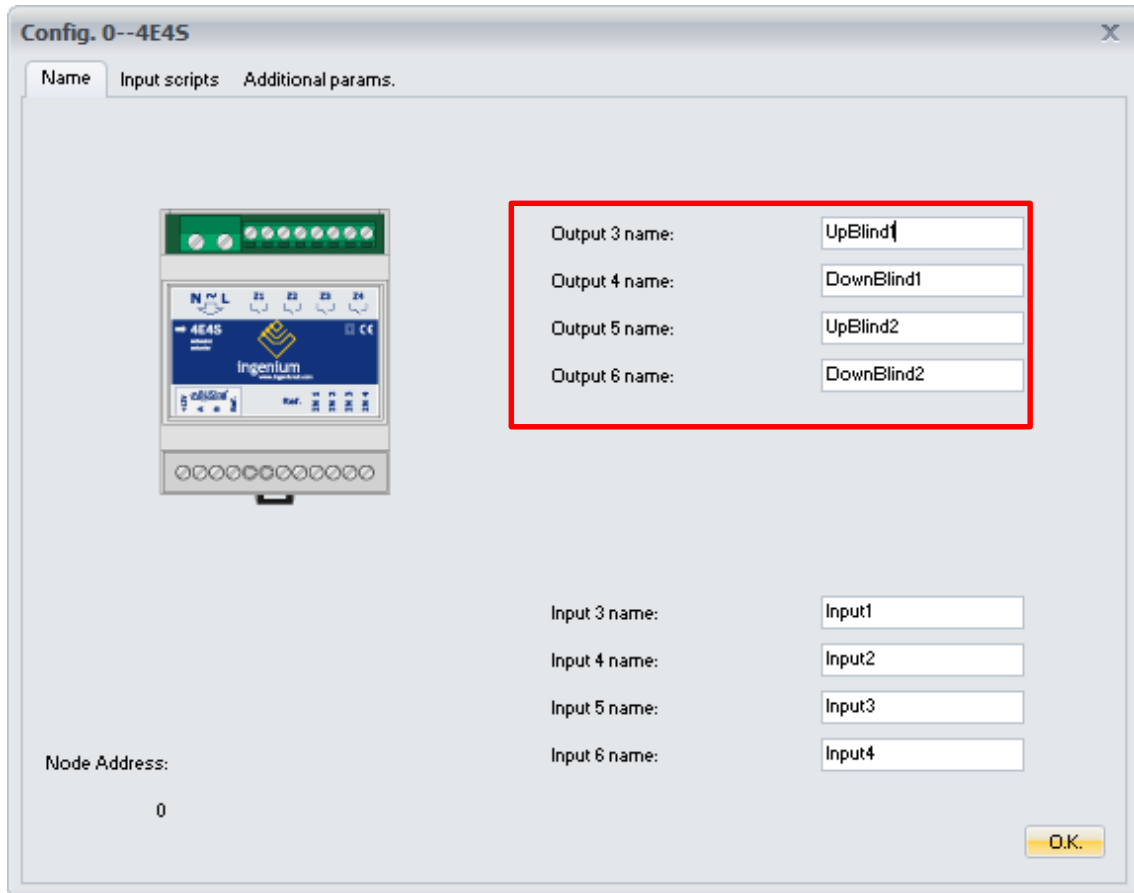

It is not normally possible to assign names to the inputs, only to the outputs in order to identify in the programming which output controls which lighting.

3.2 INPUTS SCRIPTS

In this tab, look at two sections: 'inputs scripts' and 'input mode'.

In "input mode", it is allowed to modify the mode of operation of the inputs which, by default, are configured to work as pushbuttons. It can be changed to switch or special mode (if you want to configure some inputs as push-button and some as switches. Another mode is blinds, which it is selected if 4E4S is programmed to act on them, as well as the hotel mode which are not in used anymore.

On the next image, "Input scripts" are identified with 255 numbers on each gap. This means, the device inputs has no programming.

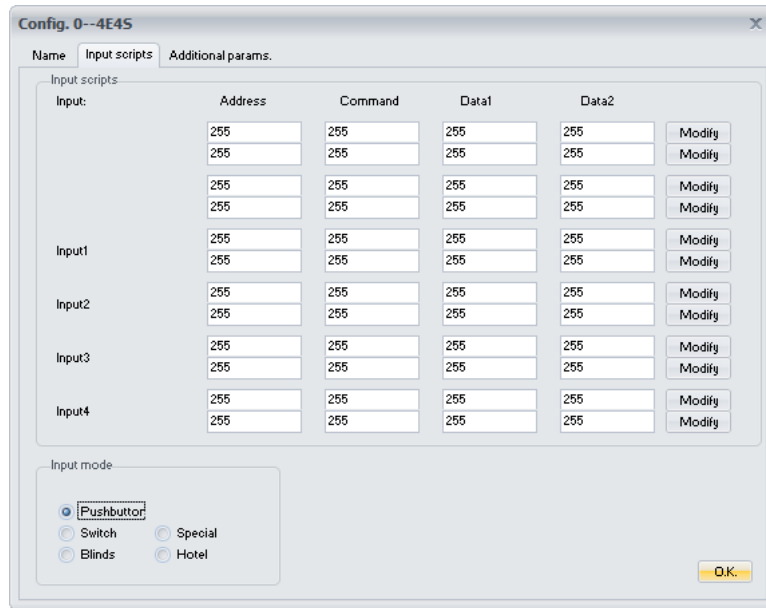

Name	Address	Command	Data1	Data2	
Input:	255	255	255	255	Modify
	255	255	255	255	Modify
Input1	255	255	255	255	Modify
	255	255	255	255	Modify
Input2	255	255	255	255	Modify
	255	255	255	255	Modify
Input3	255	255	255	255	Modify
	255	255	255	255	Modify
Input4	255	255	255	255	Modify
	255	255	255	255	Modify

Input mode:

Pushbutton
 Switch Special
 Blinds Hotel

OK

Four parts can be observed and are:

- **Address:** In this column the address of the device programmed is written.
- **Command:** In this column number 4 is assigned, corresponding to 'Write' command.
- **Data 1:** In this section, depending on the type of programming that is to be allocated, either for the control of blinds or illumination, or for the mode of operation of the input (push, switch...), one type of data or any other type shall be indicated in order to act in one form over the relay indicated in the column reserved for Data 2.
- **Data 2:** In this section, the relay is assigned the relay to be checked (opening/closing) by some numbering, according to registers manual.

3.2.1 PROGRAMMING FOR LIGHTING CONTROL:

If in the 'installation modules' tab is included a 4E4S in address 0 and will be programmed for lighting controlled, next steps should be followed.

In the 'inputs scripts' tab, there are "Modify" buttons on the right side of the screen, through which it will be able to program the actuator, in this case, to act on the illumination.

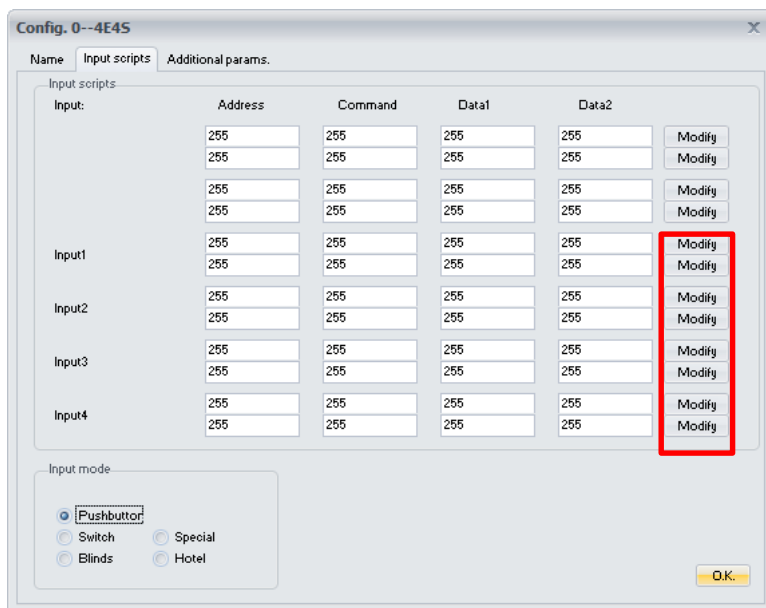

Each of the “Modify” button corresponds to the corresponding row where it is located.

At the left-hand side of the screen there are two lines for commands for each input (input 1, 2, 3 and 4). On the first one, opening of the output relay will be programmed and the other for closing the relay. A small example is explained:

In input 1, has to control the opening and closing of the relay from output 1 (relay 0) as follows.

Click on the “Modify” button on the first row.

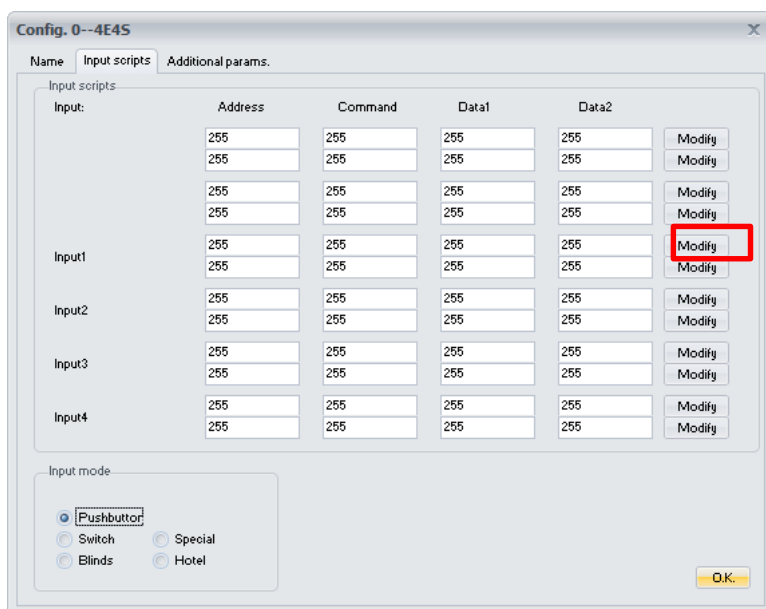

Then, it appears a node selection screen, where it can be chosen the device itself on which it is being acting, in this case the 4E4S.

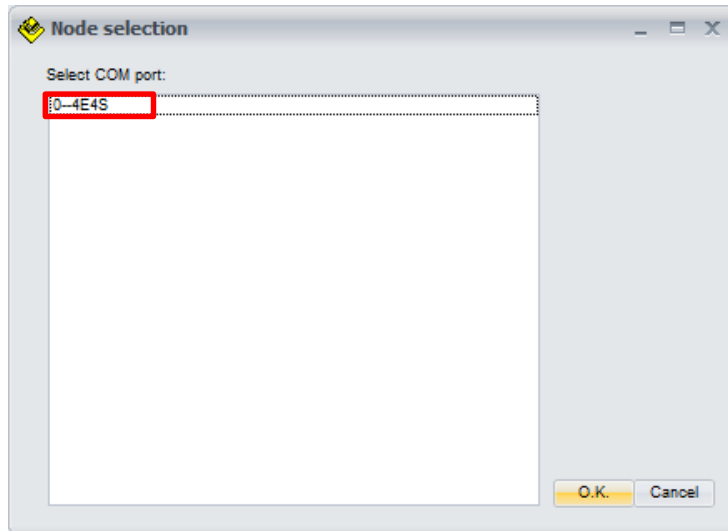

When click OK, next screen will be shown.

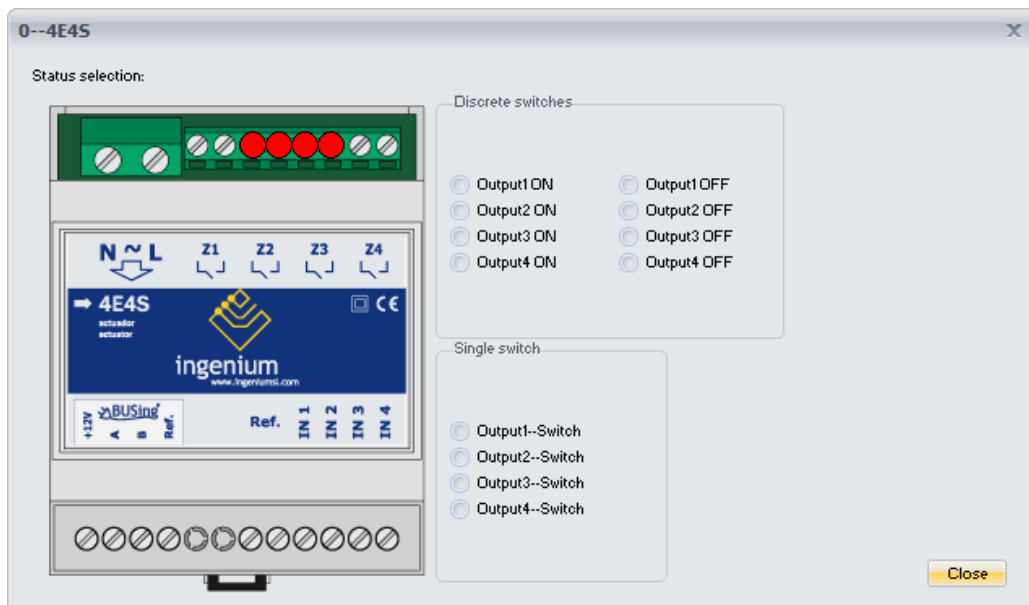

There are at two sections:

- **Switched on/ off:**
In this section there are two columns for action, one for opening (left column) and one for closing (right column) the relay.
- **Switch an output:**
In this section there is only one column to choose the corresponding output for the Switch or change of status.

In this case, the option shown below is chosen.

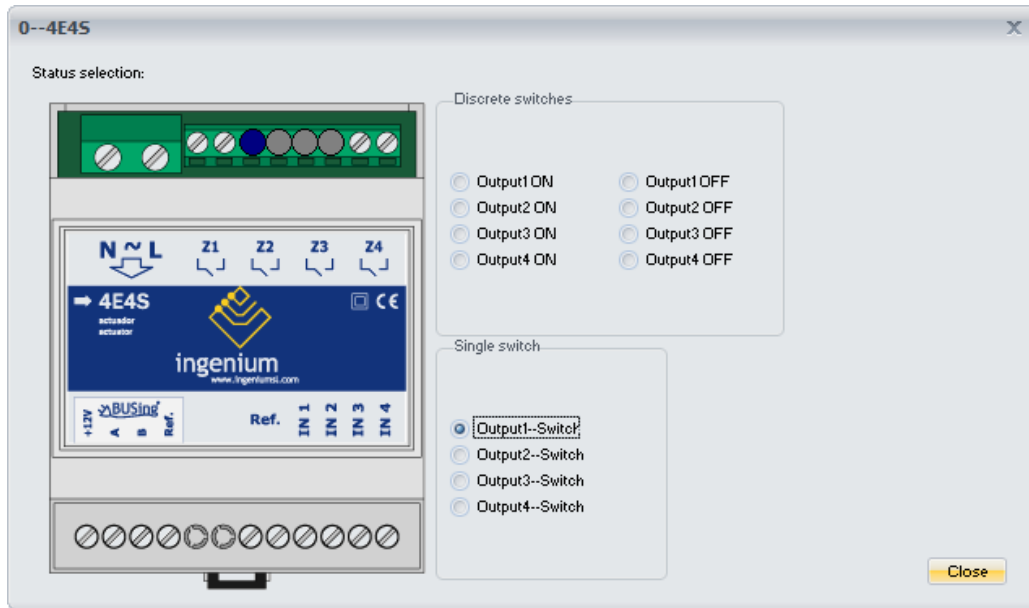

Click on Close, and observe that in the 'input scripts' tab, the row has changed.

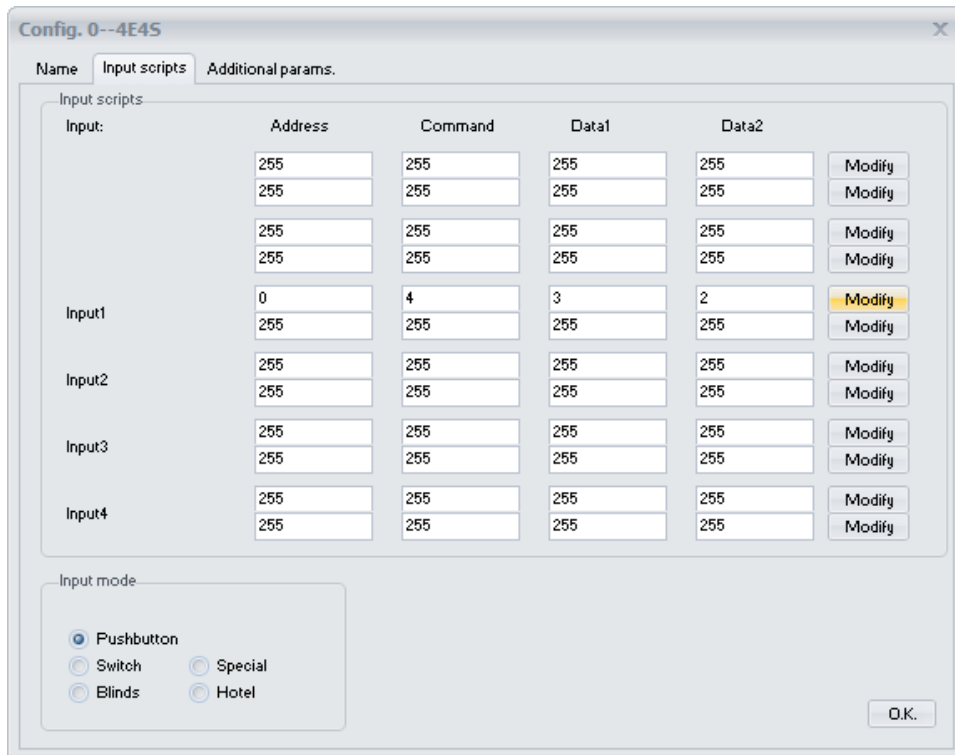

Click on the "Modify" button on the second row by selecting again the 4E4S on the node selection screen and choosing the next configuration.

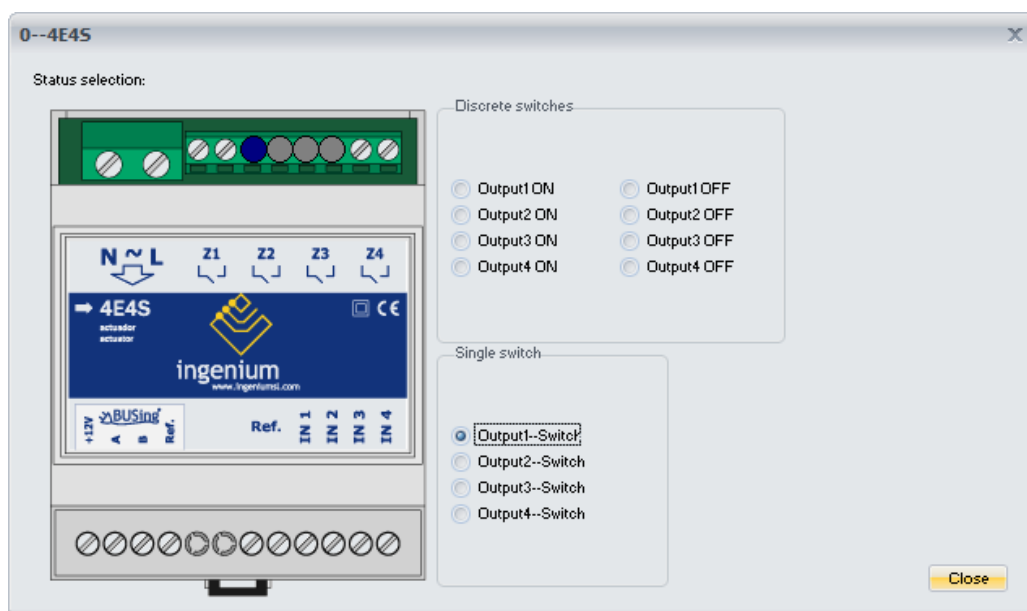

Press Close and note that the second row has new commands, and that they are exactly the same as those of the first row.

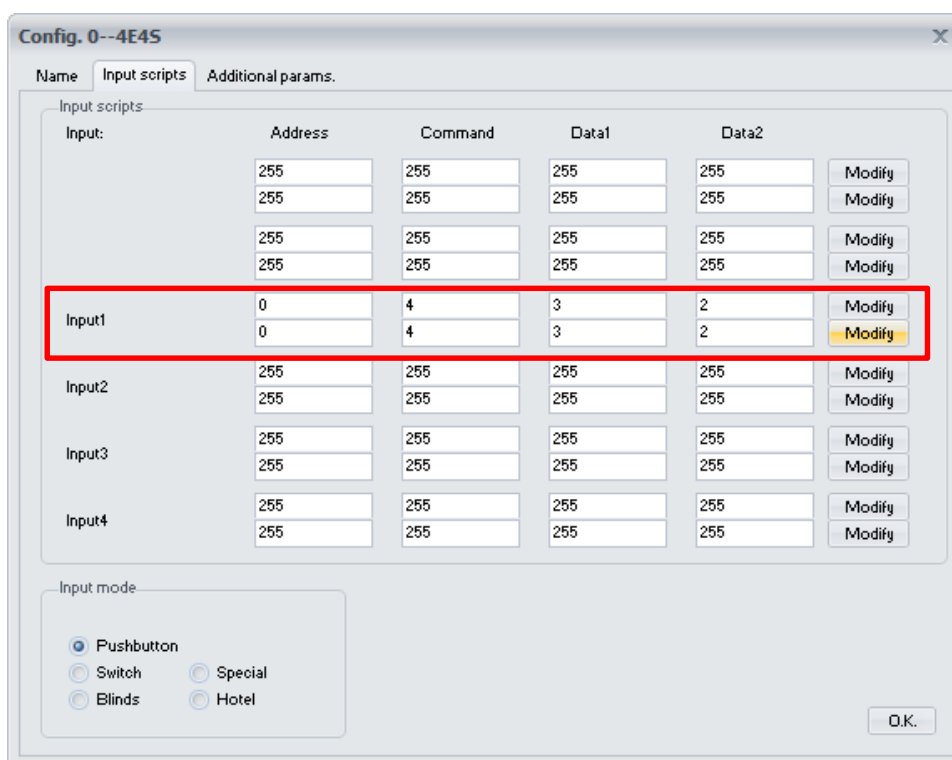

EXPLANATION:

It was programmed a Switch or change of status on output 1 (relay 0). The script is the following:

- Address: 0 It is the address of the 4E4S itself.
- Command: 4, Write command is the command that allows to take an action on the outputs.
- Data 1: 3 makes a Switch on the relay indicated in Data2.

- Data 2: 4 Indicates the relay on which the Switch is being doing. This number can be checked on the registers manual.

Therefore, when it is acted on the 4E4S, from a push-button or switch, a MECing, a touch screen... the following it is done:

1º Switch or position 1 of the switch: The first row is executed. If first relay (output 1) is open (light off) comes to be closed (light on), i.e. change status (switch).

2º Switches or position 2 of the switch: The second row is executed. If first relay (output 1) is closed (light on), it is switched to opening (light off), i.e. changes to status (switch).

3rd touch: The first row would be executed again. Changing the state of the relay.

4nd touch: The second row would be executed again. Changing the state of the relay.

And so on. In that case, what would be able to achieve with this is that with one pulsation, the light is turned on and with the next one is switched off (by changing the previous state), in the next turn on...

For the next input, 2, the same should be done. Choosing on each individual case the corresponding output, as shown below:

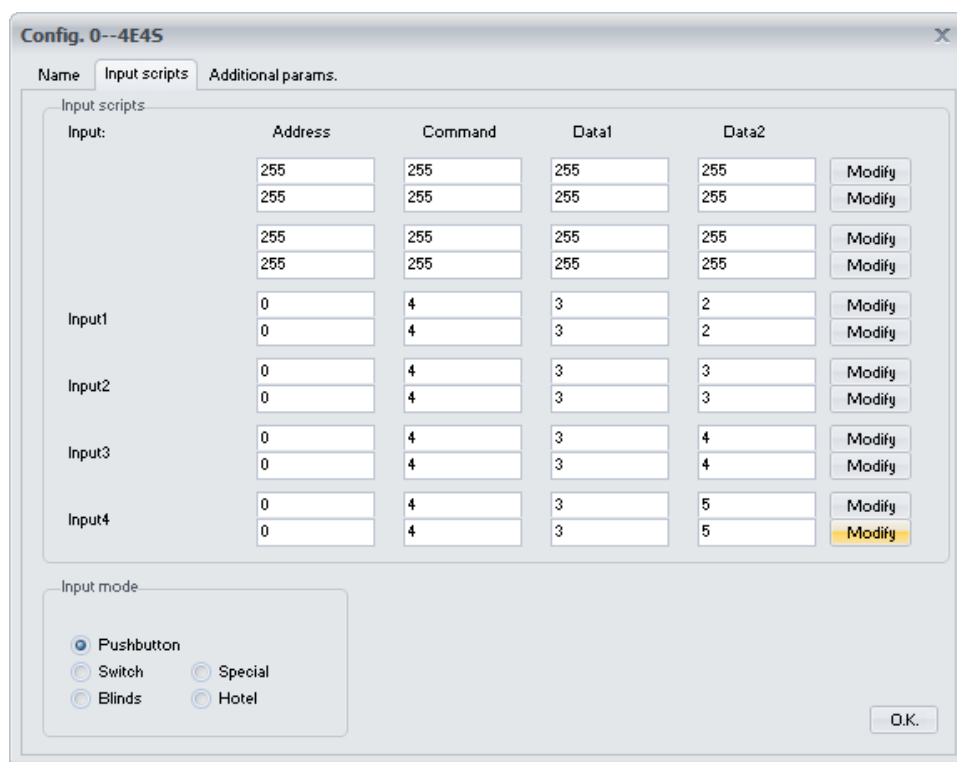

The screenshot shows a software window titled "Config. 0--4E4S" with three tabs: "Name", "Input scripts", and "Additional params.". The "Input scripts" tab is active, displaying a table of input configurations. The table has columns for "Input:", "Address", "Command", "Data1", "Data2", and "Modify".

Input:	Address	Command	Data1	Data2	Modify
	255	255	255	255	Modify
	255	255	255	255	Modify
	255	255	255	255	Modify
	255	255	255	255	Modify
Input1	0	4	3	2	Modify
	0	4	3	2	Modify
Input2	0	4	3	3	Modify
	0	4	3	3	Modify
Input3	0	4	3	4	Modify
	0	4	3	4	Modify
Input4	0	4	3	5	Modify
	0	4	3	5	Modify

Below the table, there is an "Input mode" section with four radio buttons: "Pushbutton" (selected), "Switch", "Blinds", and "Special". There is also a "Hotel" radio button. An "O.K." button is located at the bottom right of the window.

NOTE: THE PREVIOUS PROCEDURE CAN BE PERFORMED BY TYPING THE COMMANDS (NUMBERS FROM EACH SECTION) DIRECTLY ON THE CORRESPONDING BOXES, WITHOUT SIMPLY DELETING 255 AND WRITING THE RIGHT THING.

NOTE: AS SHOWN IN THE UPPER IMAGE, THE FIRST EIGHT COMMANDS, CORRESPONDING TO THE OTHER FOUR/TWO INPUTS USED ON 6E6S AND 4E4S, WHICH ARE NOT USED IN A 4E4S.

Below is a table summarizing the mode of operation of the inputs using the two most common devices for action on lighting and blinds, switches and push-buttons.

For illumination, when programming with a Switch (Dato1 = 3) or by opening/closing relay (Dato1 = 2; Dato2 = 4-5 (open); Dato2 = 12-13 (close), can be chosen:

Device \ Mode	pushbuttons	switch
pushbuttons	<p>During the first click, events from box 1 are executed and the second pulsation events from box 2.</p> <p>In box 1 and 2, can be different events.</p> <p>Maximum of 6 scenes</p>	<p>By clicking first time events from box 1 are executed and when releasing the events from box 2.</p> <p>In box 2 should be the same scripts as in box 1 or no scripts.</p> <p>A maximum of 3 scenes.</p>
switch	<p>When clicking on the first position of the switch, the events from box 1 are executed and when clicking on the second position of the switch, it does not perform anything. By clicking on the upper side of the switch, box 2 would be implemented. When clicking again the lower part does not execute anything.</p> <p>This combination is not feasible.</p>	<p>When clicking on top of the switch, the events in box 1 are executed and when clicking the below position executes the events in box 2.</p> <p>A maximum of 6 scenes.</p>
		
<p>As has been discussed above, the implementation of the scenes is made two to two per columns: 1 and 2, 3 and 4, 5 and 6. For the table above, the explanation is fully valid instead of for boxes 1 and 2, for 3 and 4 or for 5 and 6.</p>		

3.3 ADDITIONAL PARAMETERS

Three parameters appear, which will be described below.

Config. 0--4E4S

Name Input scripts Additional params.

Input params.

Input filter: 4 Cycles (6 by def)

Short pulse: 10 1/10 secs (10 by def)

Parametros Persianas

Tiempo Persiana 2: Segundos.

Tiempo Persiana 3: Segundos.

O.K.

Input filter: in this field time is introduced time in cycles, below to which pushbutton execution is not considered as such. I.e.:

- 1 cycle = 20 milliseconds
- By default: 6 cycles.
- $6 \times 20 \text{ ms} = 180 \text{ ms}$

In case of pushing the pushbutton and such pulsation would be extremely quick, less than 180 ms, the device would not perform any action.

The reason for this is to avoid false pulses and therefore executing events associated with these pulsations because of current or voltage (electrical noise). 6 cycles are sufficient time to avoid such cases.

Short pulsation: this parameter is pulsation time from blind would move to the highest position or the lowest. Check on “general description”. NOTE: 30 tenths of a second = 3 seconds.

Blinds time: it is the time the relay remains closed, whether or not the blind has reached the limit. The value introduced here is the result of counting the time that takes a blind moving from the lowest position to the highest position, and vice versa. This can return a different value for rise time and down time. In this case, average should be calculated and introduce that value on the box.

Once the actuator is programmed and working, the blind time introduced on SIDE is the time of movement from 1% to 99%, or vice versa.

However, between 0 and 1%, and 99% and 100% there is an extra time, in order to assure the end of the blind, defined internally on the actuator.

4 DEVICE DIAGNOSTICS

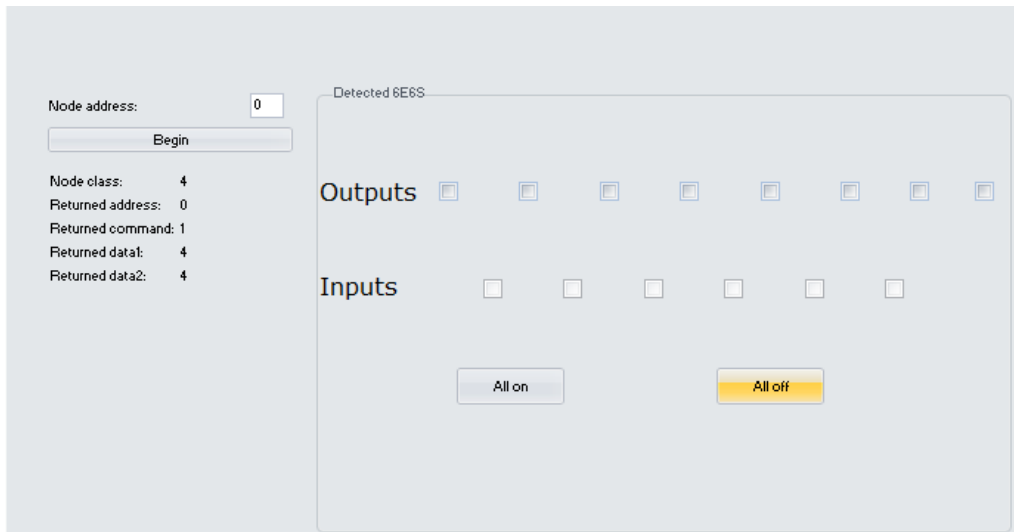

In the diagnostic tab, a communication with the device can be established and check its status.

In this case, it is a 4E4S with address 0. Take into account that all different actuators respond to diagnosis as in the image (with 8 outputs and 6 inputs).

NOTE: ALL DEVICES RESPONDS TO ADDRESS 255, IN ADDITION TO THE ONE THEY HAVE ADDRESSED. A SINGLE DEVICE, MAKE A DIAGNOSTIC TO ADDRESS 255, TO GET TO KNOW YOUR ADDRESS.

Known the address, it is written in the section “Node address”, and clicking on “begin” button reveals the following data:

- **Type of node:** 4. Each device has a type of node, in the case of 4E4S, number 4.
- **Address returned:** 0. It returns the address of 4E4S, indicating that it is perfectly communicated.
- **Return command:** 1. It’s a ACK, i.e. OK. The device communicates well. If it would be 2 means “NO ACK” and the device would have an error of communication.
- **Data 1** returned 4. it returns the node’s reading.
- **Data 2** returned: not relevant.

Also on the right side of the screen:

- **Outputs:** it is possible to act (activate/deactivate) separately for each of the outputs just clicking on each of the boxes. Each box corresponds to an output from the device. If device is 6E6S, the outputs correspond to the outputs for each of the 6 outputs, the first of which is most to the left. For a 4E4S, only the 4 boxes on the right-hand side would be relevant (the first output would then be the third box, beginning on the left hand side). For 2E2S, outputs correspond to boxes 5 and 6 (starting on the very left side).
- **Inputs:** the status of the inputs can be checked, i.e. check that the input is activated for the control of 4E4S.
- **Activate all:** activate all the outputs.
- **Switch off All:** deactivate all the outputs.

To change these values, click on “Begin” every time you want to update.

5 REGISTERS

5.1 RAM

Command	Data 1	Data 2	Description
Read	0	0	Read the state of inputs. The result is answered in data1 of the ACK telegram. Decimal value encoded according to table 5.2.1. Bit = 0 input activated. Bit = 1 input deactivated.
Read	1	0 - 255	Read the state of outputs. The result is answered in data1 of the ACK telegram. Decimal value encoded according to table 5.2.2. Bit = 1 output activated. Bit = 0 output deactivated.
Write		0 - 255	Set the state of every output at the same time according to the decimal value indicated in data2, encoded as table 5.2.2.
Write	2	0 - 7 8 - 15	Actuate over each output independently. 8S: data2 = 0 to 7 activate outputs 1 to 8. data2 = 8 to 15 deactivate outputs 1 to 8. 6E6S: data2 = 0 to 5 activate outputs 1 to 6. data2 = 8 to 13 deactivate outputs 1 to 6. 4E4S: data2 = 2 to 5 activate outputs 1 to 4. data2 = 10 to 13 deactivate outputs 1 to 4. 2E2S: data2 = 4 to 5 activate outputs 1 to 2. data2 = 12 to 13 deactivate outputs 1 to 2.
Write	3	0 - 7	Change the state of an output. The actual state is checked and it is internally changed automatically. 8S: data2 = 0 to 7 switch outputs 1 to 8. 6E6S: data2 = 0 to 5 switch outputs 1 to 6. 4E4S: data2 = 2 to 5 switch outputs 1 to 4. 2E2S: data2 = 4 to 5 switch outputs 1 to 2.
Read / Write	4	0 - 100	Opening percentage position of the blind. 8S: 1 st blind (outputs 1 and 2). 6E6S: 1 st blind (outputs 1 and 2).
Read / Write	5	0 - 100	Opening percentage position of the blind. 8S: 2 nd blind (outputs 3 and 4). 6E6S: 2 nd blind (outputs 3 and 4). 4E4S: 1 st blind (outputs 1 and 2).
Read / Write	6	0 - 100	Opening percentage position of the blind. 8S: 3 rd blind (outputs 5 and 6). 6E6S: 3 rd blind (outputs 5 and 6). 4E4S: 2 nd blind (outputs 3 and 4). 2E2S: 1 st blind (outputs 1 and 2).

Read / Write	7	0 - 100	Opening percentage position of the blind. 8S: 4 th blind (outputs 7 and 8).
--------------	---	---------	---

TABLE 5.1.1

5.2 EEPROM

Command	Data 1	Data 2	Description
ReadEeprom	0	0 - 255	BUSing [®] address of the device.
ReadEeprom / WriteEeprom	2	0 - 22	Inputs digital filter.
ReadEeprom / WriteEeprom	3	0 - 255	6E6S, 2E2S, 4E8S: blind time of 1 st blind (in sec). Devices previous to 15/04/2016 counted the same time in all blinds. On Rejibus-Z: time = data2/2. If data 2 = 2, it is equivalent to 1 sec. Data 2 = 0 – 80(max. time 40 sec, corresponding to data 2 = 80)
ReadEeprom / WriteEeprom	4	0 - 255	Short pulsation time in blind mode measured in seconds. Pulsation shorter than time = open / close step by step. Pulsation longer than time = open / close completely.
ReadEeprom / WriteEeprom	5	0 - 255	6E6S, 4E8S: Blind time of 2 ^o blind (in seconds). 4E4S: Blind time of 1 ^o blind (in seconds).
ReadEeprom / WriteEeprom	6	0 - 255	4E8S: Blind time of 3 ^o blind (in seconds). 6E6S: Blind time of 3 ^o blind (in seconds). 4E4S: Blind time of 2 ^o blind (in seconds).
ReadEeprom / WriteEeprom	7	0 - 255	4E8S: Blind time of 4 ^o blind (in seconds).
ReadEeprom / WriteEeprom	9	0 - 255	Set the working mode of the inputs. Data 2 = 0 Inputs in pushbutton mode. Data 2 = 1 Inputs in switch mode. Data 2 = 2 Blind mode. Data 2 > 3 Special mode. Some inputs in pushbutton mode and others in switch mode. According to table 5.2.1. Bit = 1 corresponding input in switch mode. Bit = 0 corresponding input in pushbutton mode.

TABLE 5.2.1

5.2.1 INPUTS TABLE

	Bit 7	Bit 6	Bit 5	Bit 4	Bit 3	Bit 2	Bit 1	Bit 0
8S	-	-	E4	E3	E2	E1	-	-
6E6S	E6	E5	E4	E3	E2	E1	-	-
4E4S	E4	E3	E2	E1	-	-	-	-
2E2S	E2	E1	-	-	-	-	-	-

TABLE 5.2.1

Bit = 0 corresponding input activated.
 Bit = 1 corresponding input deactivated.

Example: If read telegram is sent by data1 = 0 to a 6E6S (address 1) whose inputs 2 and 4 are activated, the device answers the following.

From 254 to 1, Command: 3, Data1: 0, Data2: 0.

From 1 to 254, Command: 1, Data1: 212, Data2: 212.

The device answers the state of the inputs in the ACK (command 1), being data1 a decimal value that must be changed to binary according to the table 5.2.1:

	E6	E5	E4	E3	E2	E1	-	-
212 =	1	1	0	1	0	1	0	0

5.2.2 OUTPUTS TABLE

	Bit 7	Bit 6	Bit 5	Bit 4	Bit 3	Bit 2	Bit 1	Bit 0
8S	Z8	Z7	Z6	Z5	Z4	Z3	Z2	Z1
6E6S	-	-	Z6	Z5	Z4	Z3	Z2	Z1
4E4S	-	-	Z4	Z3	Z2	Z1	-	-
2E2S	-	-	Z2	Z1	-	-	-	-

TABLE 5.2.2

Bit = 1 corresponding output activated.
 Bit = 0 corresponding output deactivated.

Example: In case of wanting to activate outputs 3 and 5 of a 6E6S (address 1), and deactivate the others, the following telegram must be sent:

From 254 to 1, Command: 4, Data1: 1, Data2: 20.

When data1 = 1 is sent, the device sets the state of its outputs at the same time, according to the decimal value indicated in data2, encoded as indicated in table 5.2.2.

	Z8	Z7	Z6	Z5	Z4	Z3	Z2	Z1
20 =	0	0	0	1	0	1	0	0

6 DATA LOADING TO DEVICE

6.1 WIRING DEVICE

It is needed to have the 4E4S correctly connected as follows:

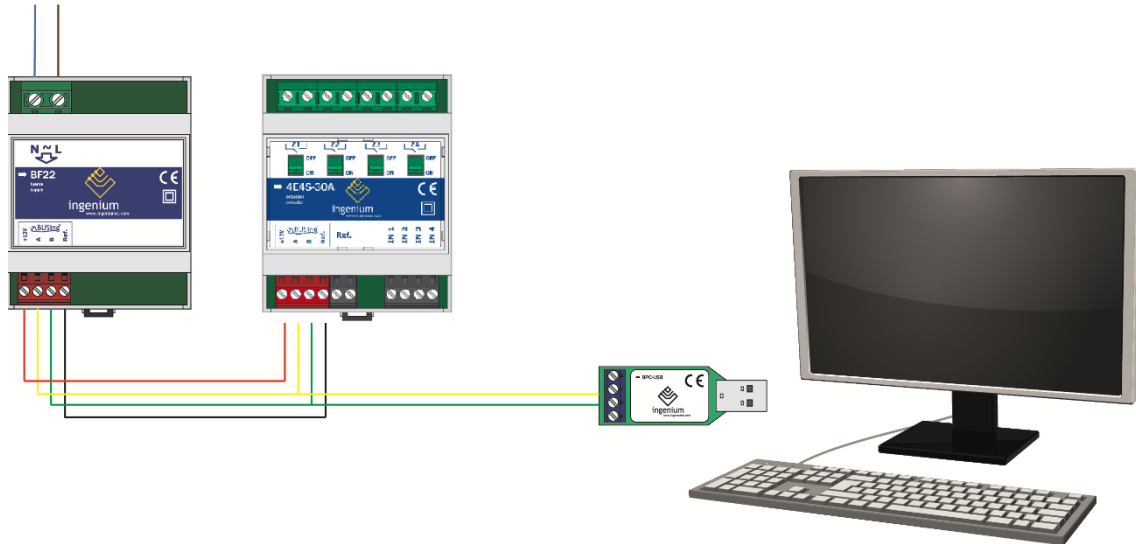

NOTE: IT IS NOT NECESSARY TO PLACE THE POWER SUPPLY IF THERE IS SUFFICIENT VOLTAGE IN THE INSTALLATION TO FEED IT. IT MAY BE THAT THE FEED COMES FROM OTHER DEVICE SUCH AS 6E6S, 4E4S... ETC.

The device is located in the modules of the installation of SIDE. Right click on it and choose to re-program this node, using the following screen where click on “Program”.

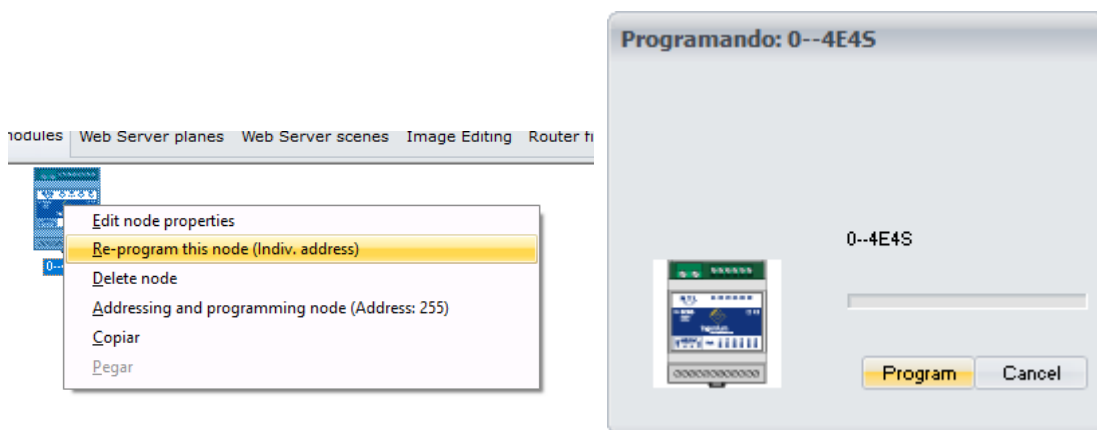

Wait until the bar on top Program button reach the end so the device has the data downloaded.

7 WIRING

4E4S-30A output wiring

Maximum power per output, 30A resistive load.

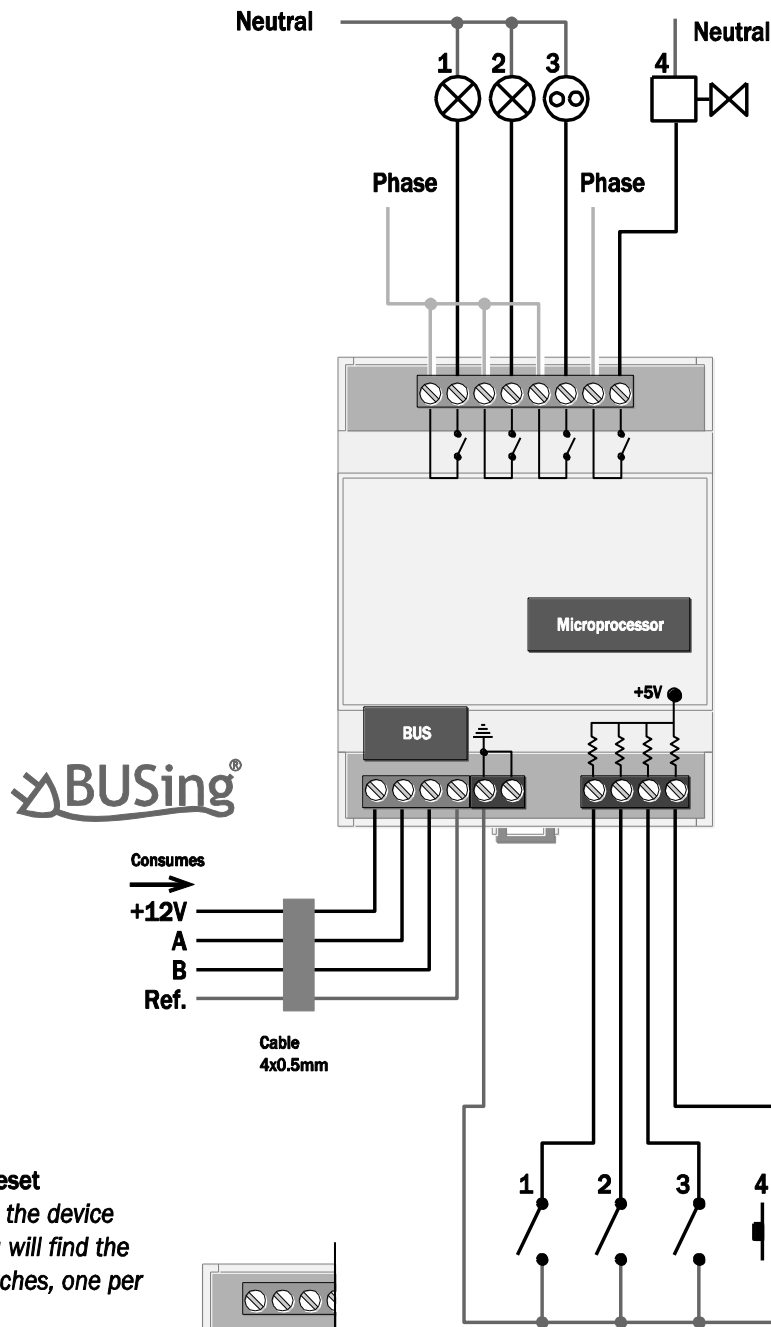

Manual reset
Lifting up the device cover you will find the relay switches, one per output

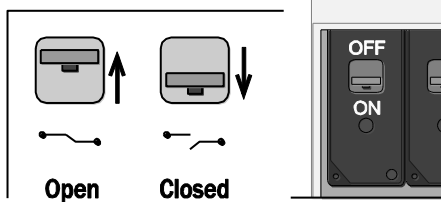

4E4S-30A input wiring

All inputs are SELV.

They are internally referred to 5V and they are activated when connected to Ref.



Parque Tecnológico de Asturias, Parcela 50,
33428 Llanera – Asturias - España

Tel (+34) 985 118 859

Fax (+34) 984 283 560

ingeniumsl@ingeniumsl.com

www.ingeniumsl.com

